

Installation and Maintenance of A.R.I.'s D-062 HF Combination Air Valves



A. Installation

- A.1 The air valve will be mounted on a riser, connected to the **top** of the pipe.
- A.2 An isolating valve will be installed below the air valve.

B. Basic, Periodic, Maintenance

- B.1 Shut the isolating valve below the air valve.
- B.2 Unscrew the body of the Automatic air valve (1).
- B.3 Remove the Clamping Stem and the float in the automatic component and wash the inside of the body, the Clamping Stem, the float, and the Rolling Seal, with clean water.
- B.4 Check to make sure the Rolling Seal is unharmed (not torn or cracked) and is attached precisely in the middle of its groove in the float.
- B.5 Unscrew the bolts (15) that connect the main valve cover (11) to its body (17).
- B.6 Wash the body, the screen and the cover in clean water in order to remove coarse grime or accumulated scale.
- B.7 Reinstall in reverse order and fasten and tighten all bolts. Make sure to re-assemble the upper air valve correctly: First, insert half the length of the rolling seal tail into its groove in the body (1), and then, push the rest of the way, to the end of the groove, using the Clamping. Make sure the Rolling Seal is set in place.
- B.8 Open the isolating valve beneath the air valve.

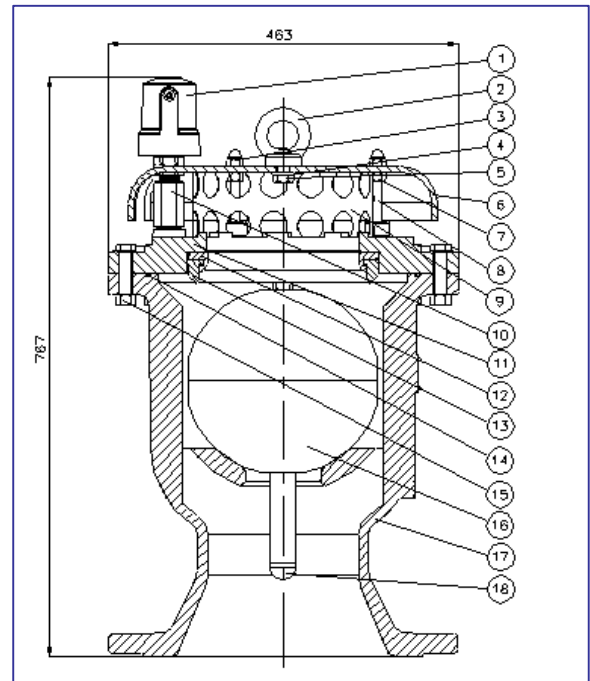

Parts Specification

1.	S-052 Body	Ductile Iron
2.	Lifting Ring	Steel Cadmium Plated
3.	Crown Nut	Stainless Steel ASTM A 276
4.	Washer	Stainless Steel ASTM A 276
5.	Bolt	Stainless Steel ASTM A 276
6.	Screen cover	Cast Iron ASTM A48
7.	Nut	Stainless Steel ASTM A 276
8.	Bolt	Stainless Steel ASTM A 276
9.	Screen	Stainless Steel SAE 304
10.	Nipple	Brass
11.	Cover	Ductile Iron
12.	Nozzle Seat	St.St. SAE 403 or 316
13.	Nozzle Seal	Buna- N or E.P.D.M.
14.	O-ring	Buna- N
15.	Bolt & Nut	Stainless Steel ASTM A 276
16.	Float	Stainless Steel SAE 316
17.	Body	Ductile Iron
18.	Plastic Plug	Plastic